

9KG33

## 1.5 MODUL GAS OVEN/CABINET COOKER

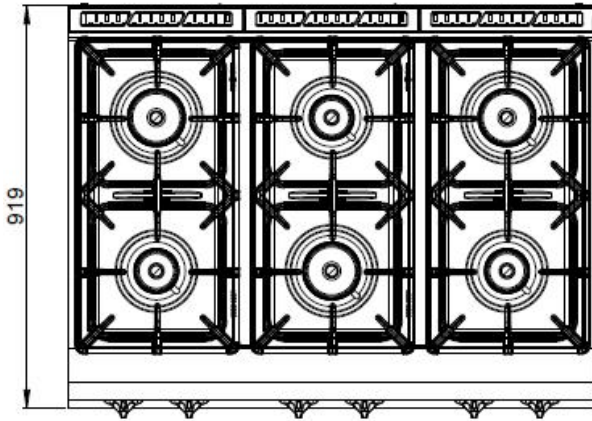
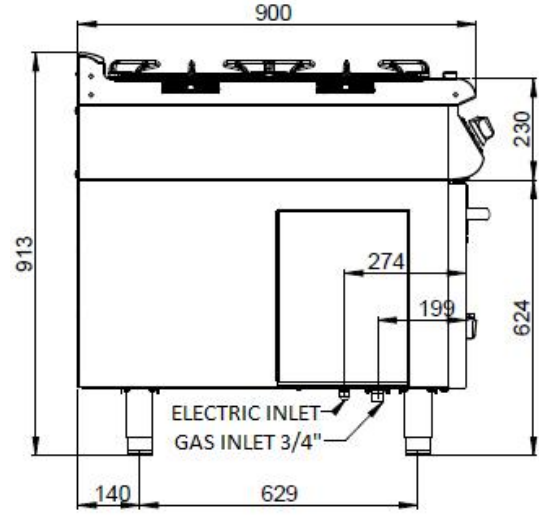
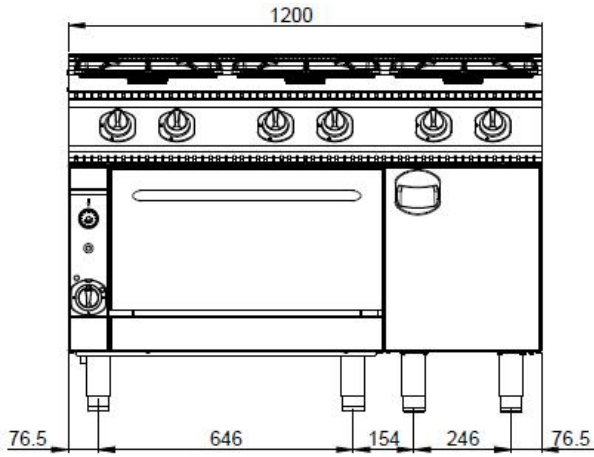

## GENERAL FEATURES

- Cooker
- Perfect 900 line, 1.5 module, with cabinet
- External surfaces of 18/8 Cr-Ni s/s satin finished sheet,
- All of the sheets and which are not exposed are of aluminized sheet,
- All of the electric board and control devices including plates in conformity with the international standards,
- It produces with cabinet as standart. Cabinet are manufactured from stainless stell. Cabinet doors are with plastic holder.
- Separate operation of the plates at different positions by 4 step switches,
- It is manufactured with cabinet as standart. Cabinet is manufactured from stainless stell. Cabinet doors are with plastic holder,
- On cupboard (with or without doors) suitable for multi-pupose use or on cantilever for island type installations .
- Adjustable feet of stainless stell pipe , carrier sheet is 2 mm aluminized sheet..
- Inside of AISI 430 BA sheet and with 3 tray slides,
- It has turbo cooking property,
- AISI 430 BA bottom sheet specially designed for homogeneous heat distribution

## TECHNICAL SPECIFICATION

Total Power	53,5	kW
Cooker Power	45	kW
Boiler (Cooker)	Ø100 / Ø130	mm
Boiler (Cooker)	3*6 / 3*9	Ad/kW
Oven Power	Ø50	mm
Boiler (Oven)	1 / 8,5	Ad/kW
Consumption	46010	Kcal/h
Gas Inlet	R3/4	Inch
Palett+Box Measures	1222x937x1006	WxDxH