

9LG20 1 MODUL GAS CABINET CHARCOAL GRILL

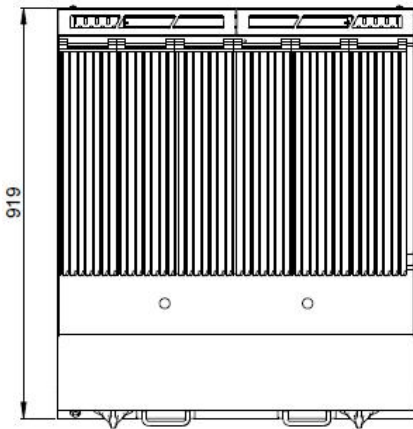
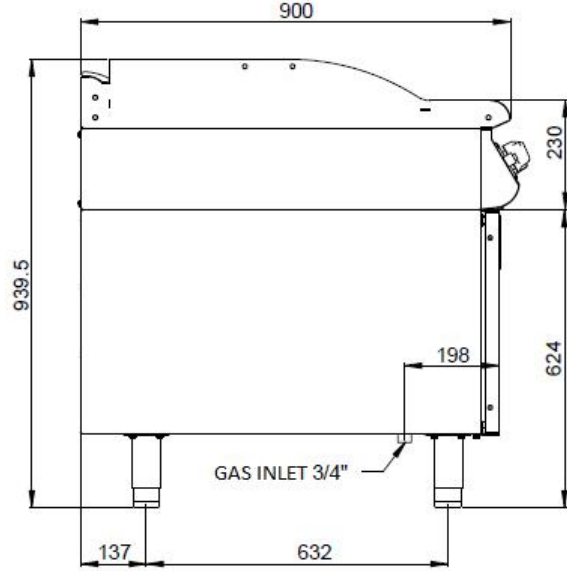
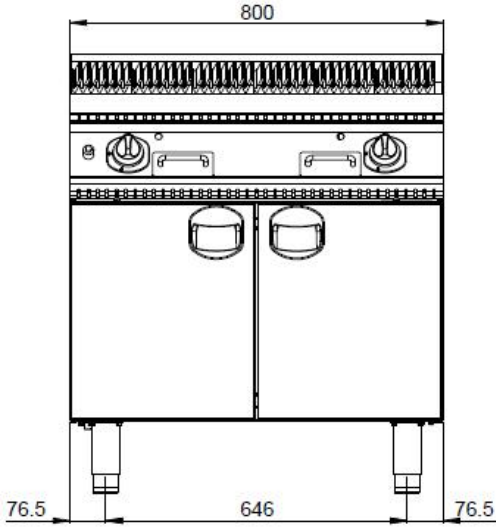

GENERAL FEATURES

- Charcoal grill
- Perfect 900 line, 1 module, with cabinet,
- Body manufactured of 18/8 Cr-Ni s/s satin finished sheet and inner parts of aluminized steel,
- Oil collecting channel and discharge in front of the frying surface,
- Collecting of oil on the surface in an easy to clean s/s drawer,
- Surface of frying can be control with two different control system,
- Upstands at 3 ends in order to prevent fat from splashing around during frying process ,
- Gas taps with the pilot flame, minimum-maximum flame and in case the flame turns off, it stops the supply of gas automatically ,
- Pipe type of gas burner suitable for operation with all types of gas,
- Automatic ignition button,
- Either LPG or natural gas (G31, G25, G25.1, G27, G2.350) operated and conversion without modification,
- It is manufactured with cabinet as standart. Cabinet is manufactured from stainless stell. Cabinet doors are with plastic holder,
- For multi-purpose use, on a cupboard (with or without doors) or on cantilever for island type installations .
- Adjustable feet of stainless stell pipe , carrier sheet is 2 mm aluminized sheet.

TECHNICAL SPECIFICATION

Total Power	10	kW
Consumption	8600	Kcal/h
Cooker Area	795x490	mm
Gas Inlet	R3/4	Inch
Palett+Box Measures	822x937x1006	WxDxH