

# İNOKSAN

## 9ME10 ½ MODUL ELECTRIC PASTA COOKER

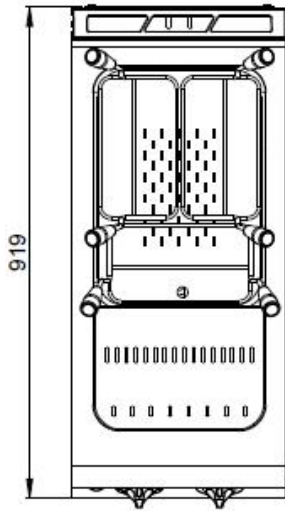
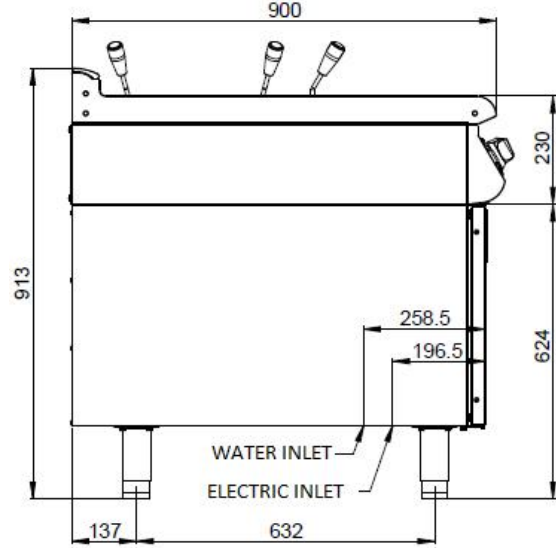
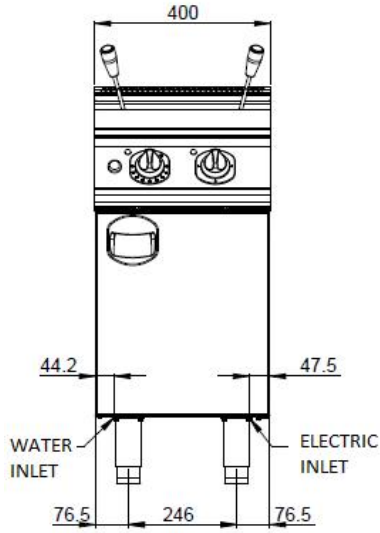

## GENERAL FEATURES

- Pasta cooker
- Perfect 900 line, 1/2 module, with cabinet,
- Manufactured of 18/8 Cr-Ni s/s satin finished sheet,
- Temperature control between 0- 110°C by multi-step thermostat,
- Main switch for supplying or stopping of power,
- All of the electric control boards and devices in conformity with the international standards ,
- Underneath 3/4" ball valve for discharging water from the well,
- Water filling tap controlled from the front panel,
- Overflow discharging to prevent overflowing of water in the well,
- It is manufactured with cabinet as standart. Cabinet is manufactured from stainless stell. Cabinet doors are with plastic holder,
- Either on a cupboard for multi-purpose use or on a cantilever for installation of island type,
- Adjustable feet of stainless stell pipe , carrier sheet is 2 mm aluminized sheet,

## TECHNICAL SPECIFICATION

Total Power	9	kW
Electric Inlet	380/400	V
Cablo Cut	5*2,5	mm <sup>2</sup>
Water Capacity	30	Lt
Palett+Box Measures	422x937x1006	WxDxH