



## REFRIGERATED TROLLEYS

- Especially designed for maintaining and serving previously prepared cold food. Ideal to replace cold chambers or refrigeration units.
- Refrigeration unit with fan built inside the chamber. A constant flow of chilled air is generated by the evaporation fans, leading to a fastest temperature drop, as well as a better, more uniform cool air distribution.
- Digital reading electronic to monitor and control chamber temperature and defrosting cycle.
- Operating temperature ranges from +2° to +8° C with a 32° C room temperature.
- Doubled wall with an injected CFC-free, ecological polyurethane 40 Kg/m3 density isolation. With its highly-insulated walls, heat transfers are reduced thus obtaining energy savings.
- Automatic locking mechanism in hinges: when door is in a position of less than a 90° angle it gets fully closed, thus avoiding rising of temperature.
- Four (4) sound-proof castors of 125 mm diameter, two of them with brakes for an easy handling and safer use. Non-marking, special rubber bumpers to protect against direct impacts in all four (4) corners.
- Key locked door.
- Made of stainless steel.
- GN 2/1 rod shelves supplied as standard depending on model: five (5) units (CF-20), ten (10) units (CF-40).
- Operating voltage and frequency: 230V/1/50HZ.



CF-40



CF-20

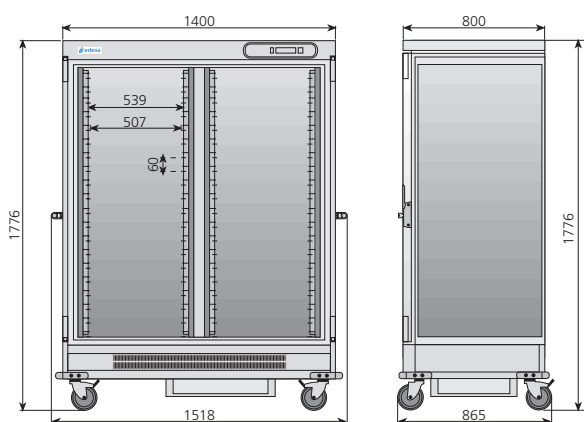

CF-40

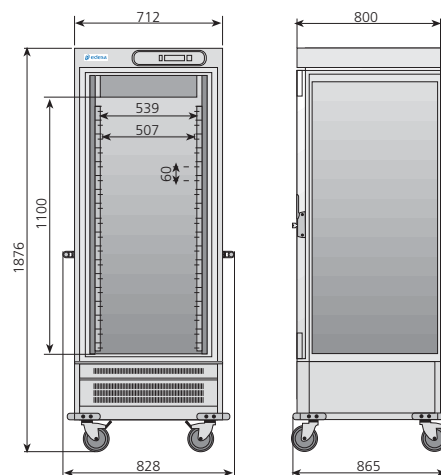

CF-20

Model	Reference	External dimensions (mm)	GN 2/1 rack capacity (60 mm distance)	GN 2/1 rack rails supplied	GN 2/1 plastic rod shelves supplied	Power (W)
CF-20	19007132	828 x 865 x 1776	17	5	5	350
CF-40	19008252	1518 x 865 x 1776	40	10	10	575