

**Family**  
COOKING EQUIPMENT STAR 90

**Section**  
BOILING PANS SINGLE JACKET AND DOUBLE WATER JAC

**Model**  
NPD98G15

**Code**  
CR0590870

### 150-LITRE DIRECT HEAT GAS BOILING PAN

Direct heat gas boiling pan constructed in AISI 304 stainless steel. Top in 20/10 thick AISI 304 stainless steel. Kettle bottom in polished AISI 316L stainless steel, walls in AISI 304 stainless steel. 150-litre kettle capacity. Filling with hot or cold water through solenoid valve activated by a switch, fixed water tap located on top. 2" safety drain tap with grip in heatproof material. Counter-balanced lid with 90° opening and handle offering front and side grip. Direct heating with AISI 304 stainless steel burners positioned outside the kettle. Gas safety valve with electric ignition on front panel. Thick insulating panels for thermal insulation of kettle. Temperature controlled by an energy regulator. Indicator leds for verifying correct appliance operation. Diameter of kettle 600 mm. Model equipped with safety thermostat with reset button accessible to the user. Height adjustable feet in stainless steel. IPX5 protection rating.



#### Technical data

Width mm:	800	Internal dim. oven mm:	
Depth mm:	900	Oven capacity:	
Height mm:	870	Oven power kW:	
Weight kg.:	124.00	Qty heating zones:	1 x 24 kW
Volume m <sup>3</sup> :	1.00	Plate dim. mm:	
Power supply:	VAC230 50Hz	Dim. heating zone mm:	
Gas power kW:	24.00	Qty tank:	
Electric power kW:	0.20	Tank dim. mm:	Ø595x597h
		Tank capacity l:	150

**Family**  
COOKING EQUIPMENT STAR 90

**Section**  
BOILING PANS SINGLE JACKET AND DOUBLE WATER JAC

**Model**  
NPD98G15

**Code**  
CR0590870

**150-LITRE DIRECT HEAT GAS BOILING PAN**

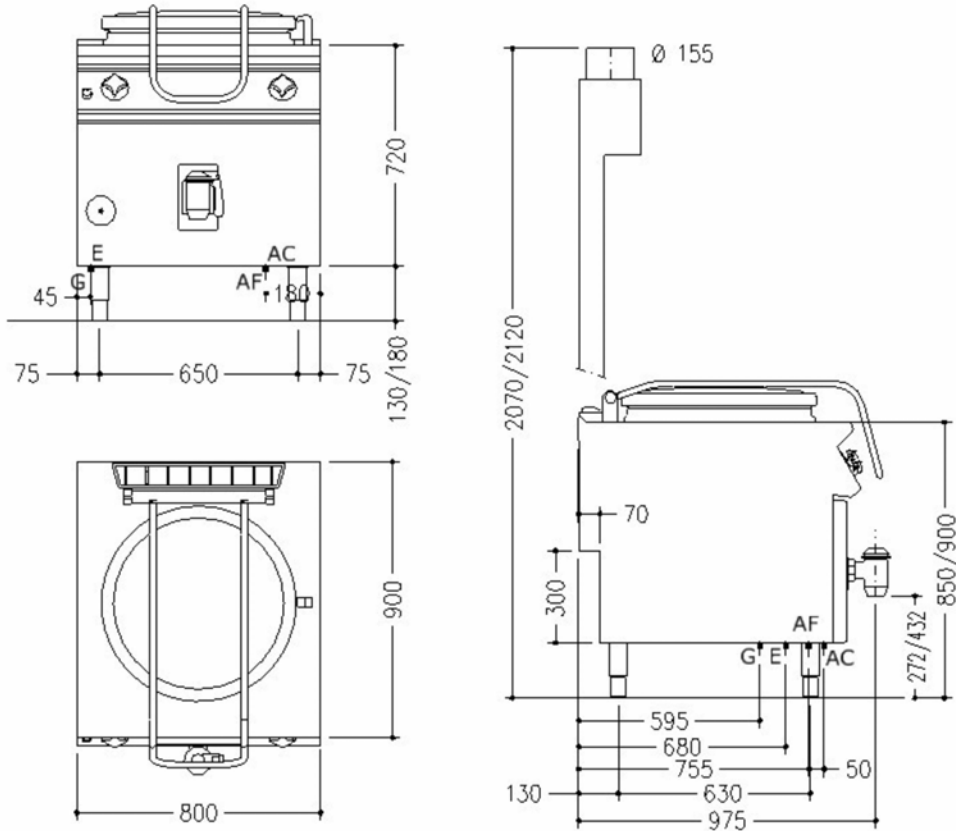

**Legend**

(E) Socket 1: Connection supply terminal floor level (+100mm). Spare cable 1500mm

(E) Socket 2:

(G) Gas: Ø1/2"- H=200mm

(AD) Softened water:

(AF) Cold water: Ø1/2"-H=200mm

(AC) Hot water: Ø1/2"-H=200mm

(S) Draining:

(FR) In e out freon:

(V) Steam: