

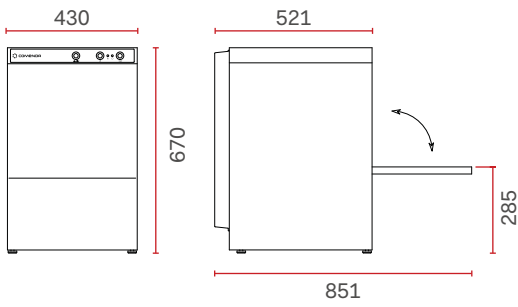

LAVABICCHIERI
GLASS WASHERS

DETTAGLI TECNICI PRODUCT SPECIFICATION

RB 33



RB 34

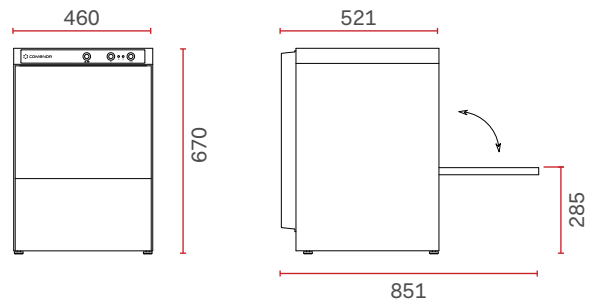

L'immagine si riferisce alla versione
con termometri.
*The image refers to the machine
with temperature indicators*





Mulinello di lavaggio
e risciacquo e filtro
vasca

*Rotating top and
bottom wash system
and tank filter*

Standard

DIMENSIONI / DIMENSIONAL DATA

	DIMENSIONI ESTERNE (LxPxH) (mm) <i>EXTERNAL DIMENSIONS (LxDxH) (mm)</i>	CESTELLO <i>RACK</i> (mm)	ALTEZZA UTILE <i>CLEARANCE</i> (mm)	PESO NETTO <i>NET WEIGHT</i> (Kg)
RB 33	430x521x670	350X350	280	37
RB 34	460X521X670	400X400		

DATI TECNICI / TECHNICAL DATA

	ALIMENTAZIONE ELETTRICA <i>POWER SUPPLY</i> (V)	DURATA CICLI DI LAVAGGIO <i>WASHING CYCLES</i> (sec)	PRODUZIONE TEORICA (cestelli/h) <i>OUTPUT</i> (rack/h)	CONSUMO ACQUA DI RISCIACQUO <i>RINSE WATER CONSUMPTION</i> (l)
RB 33	230V ~ 50Hz	90/120	30/40	2,5
RB 34				

	RESISTENZA VASCA <i>TANK HEATER</i> (kW)	RESISTENZA BOILER <i>BOOSTER HEATER</i> (kW)	POMPA DI LAVAGGIO <i>WASH PUMP</i> (kW)	POTENZA INSTALLATA <i>INSTALLED LOAD</i> (kW)	CAPACITÀ VASCA <i>TANK SIZE</i> (l)
RB 33	2	2,8	0,26	3,06	12,5
RB 34					

OPTIONAL

KIT POMPA DI SCARICO
DRAIN PUMP KIT

KIT DOSATORE DETERSIVO
DETERGENT DOSING PUMP KIT

ADDOLCITORE ESTERNO
EXTERNAL WATER SOFTENER

DISPLAY CON TERMOMETRI
TEMPERATURE INDICATORS

VOLTAGGI SPECIALI A RICHIESTA
SPECIAL VOLTAGES ON REQUEST

